

Proven design and quality

Versatile and durable



MK

Well proven sprayers

The HARDI NK sprayer is one of the most versatile sprayers ever built. The NK is used by professional plant growers all over the world. It finds its use in traditional farming, horticulture, orchards, vineyards and on grasslands.

The NK is a durable and well proven sprayer that offers far more features and options than you would expect from a sprayer in this class.

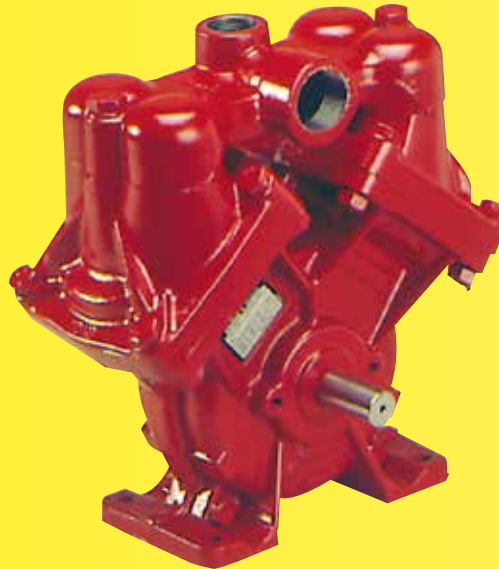

Tank

The high-impact polyethylene tank has a deep sump that ensures complete emptying of the tank. The tank design maximises liquid agitation as well as ensuring easy and efficient tank cleaning with the use of a tank cleaning nozzle. The top mounted suction filter on the 400, 600 and 800 l tanks makes it safe and easy for the operator to perform routine maintenance of the filter screen.

The NK sprayer comes standard with pressurised agitation, that ensures consistent agitation of even the most difficult mixtures.

Pump

HARDI pumps are designed for the application of chemicals and liquid fertiliser. The diaphragms separate the liquid from the vital parts of the pump such as its bearings and crankshaft, ensuring reliable and durable operation.

HARDI diaphragm pump features:

- Self-priming
- Able to run dry without damage
- Easy to service without special tools
- Grease lubricated crankcase
- Chemical resistant diaphragms and valves

Control

The NK line offers as standard the unique and reliable HARDI BK-180 control unit. This control unit comes with a long list of standard features.

- Main on/off that diverts all liquid back into the tank
- Safety valve
- Pressure filter
- Pressure gauge
- Valve for pressure agitation
- Minimum of 3 distribution valves with constant pressure system
- HARDI-MATIC for constant application rate regardless of RPM variations

All these features ensure accurate and reliable application of all plant protection chemicals.

NK



Tank: 400, 600 and 800 l high impact polyethylene
Frame: Low centre of gravity close to tractor
Diaphragm pump: Reliable, high capacity and easy to service
Operating unit: Manual operated HARDI BK-180

Booms: Manual folded 6, 8 and 10 m SB boom
Manual folded 12 m MB boom

Booms

All booms for the NK are, like the frame, zinc-phosphate treated before being coated with polyester powder. This with a proven design ensures long and reliable use of the boom.

The 6, 8 and 10 m SB booms are directly mounted to the frame. A mechanical and hydraulic boom lift makes the height adjustment easy and safe. If the NK sprayer will be used in crops with are higher than 50 cm a lift must be ordered to fulfill the EU regulations.

The 12 m MB boom features a trapeze suspension for self-stabilisation and prolonged boom life. On the SB booms they trapeze suspension is an optional.



All booms have an adjustable spring loaded break-away to protect the boom in case of accidental encounter with an obstacle in the field.

Chassis

The chassis is the base of a long lasting sprayer. The design of the NK chassis provides for a centre of gravity that is both low and close to the tractor. The design furthermore offers easy service accessibility. The NK chassis is zinc-phosphate treated before being coated with polyester powder. This ensures outstanding weather and chemical resistance on all chassis parts.

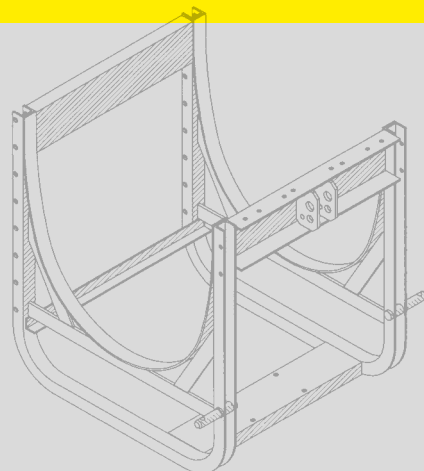

No dripping from nozzles

The single SNAP-FIT nozzle holders have a built-in non-drip diaphragm check valve. The non-drip valve ensures no dripping from the nozzles when the main on/off is closed. The SNAP-FIT system furthermore ensures that all nozzles are in the correct position.

A large range of high quality HARDI nozzles is available to suit any spray task.

Options



15 l CleanWater tank



25 l ChemFiller



60 l RinseTank



Hydraulic boom lift



TRIPLET



Foot step



Remote control



Manual boom lift

Tank size, l	Boom model, width	Pump model	Pump capacity, l/min	Size, L x W x H	Weight, kg
400	SB 6 m	603 / 1203 / 1303	42 / 99 / 114	140 x 190 x 170	150
400	SB 8 m	603 / 1203 / 1303	42 / 99 / 114	140 x 190 x 210	160
400	SB 10 m	603 / 1203 / 1303	42 / 99 / 114	140 x 190 x 210	180
600	SB 6 m	603 / 1203 / 1303	42 / 99 / 114	140 x 190 x 170	170
600	SB 8 m	603 / 1203 / 1303	42 / 99 / 114	140 x 190 x 210	180
600	SB 10 m	603 / 1203 / 1303	42 / 99 / 114	140 x 190 x 210	200
600	MB 12 m	603 / 1203 / 1303	42 / 99 / 114	140 x 190 x 220	240
800	SB 6 m	1203 / 1303	99 / 114	140 x 190 x 170	200
800	SB 8 m	1203 / 1303	99 / 114	140 x 190 x 210	210
800	SB 10 m	1203 / 1303	99 / 114	140 x 190 x 210	230
800	MB 12 m	1203 / 1303	99 / 114	150 x 190 x 220	270



*Høje Taastrup,
Denmark*



*Nørre Alslev,
Denmark*



*Savigny,
France*



*Beaurainville,
France*



*Davenport,
USA*



*Lleida,
Spain*



*Adelaide,
Australia*

HARDI - The Sprayer

HARDI INTERNATIONAL A/S is an international group whose basic idea is to satisfy the user's requirements for quality products which ensure efficient, punctual and precise application of crop protection products. Our world-wide distribution and sales network comprise more than 100 countries where we are represented by importers, agents and sales subsidiaries. These are situated in Sweden, Norway, Denmark, the UK, France, Spain, North America, Germany and Australia.

Since 1957 HARDI has committed to the ever-increasing demands for efficient and precise plant protection. HARDI is the trendsetter within application of crop protection products. To achieve this position continued developments and innovation are essential. HARDI is committed to the long term future of plant protection.



Superb surface treatment

The high-technology surface treatment contains 13 treatments, including an Oxsilan pre-treatment and powder coat painting of all major components.

Together with the Delta/Magni treatment of nuts, bolts and other items, we supply high corrosion protection of our products. The chassis, the boom and all other steel parts have been pre-treated with Oxsilan followed by a high-quality coating of powder paint.

HARDI Ltd.

Watling Suite (unit B)
High Cross Business Park
Coventry Road • Sharnford
Leicestershire • LE10 3PG
Phone: 01 455 22 22 30 • Fax: 01 455 22 22 40
E-Mail: sales@hardi-uk.com • www.hardi.co.uk

HARDI AUSTRALIA Pty. Ltd.

534-538 Cross Keys Road, Cavan • South Australia, 5094
Phone: QLD(07)3375 3544, NSW(02)96274555,
VIC(03)9310 2211, SA(08)8343 9933, WA(08)9353 2088
Email: info@hardi-aus.com • www.hardi.com.au

HARDI INTERNATIONAL A/S

Helgesvej Allé 38 • DK 2630 • Taastrup • Denmark
E-Mail: hardi@hardi-international.com • www.hardi-international.com



The Sprayer

Testing procedures

Sprayers leaving HARDI INTERNATIONAL A/S are tested according to the strictest quality standards.

The staff of the assembly line is accredited to match the demands from both NSTS (National Sprayer Testing Scheme), UK and JKI (Julius Kühn Institut), Germany. This ensures that the highest quality sprayers are delivered to farmers.



Read more at www.hardi-international.com

*HARDI reserves the right to change the specifications without notice.
Illustrations shown may include optional extras and accessories.*

