

WE150BPRO

WE170BPRO



	WE150B PRO	WE170B PRO
ENGINE POWER	90 kW - 121 hp	105 kW - 141 hp
MAX OPERATING WEIGHT	15600 - 16400 kg	17200 - 18200 kg



BUILT AROUND YOU

PRO AS PROGRESS. SETTING NEW STANDARDS

**PROGRESS FOR HIGH
SPEED, POWER
AND STABILITY**

**BRAND NEW
CONTROLS FOR A
MULTI-FUNCTION
MASTER**



IN PRODUCTIVITY, VERSATILITY, RELIABILITY

**PROGRESS IN EASY
OPERATION AND
COMFORT**

**EASY SERVICEABILITY
FOR MAXIMUM
UPTIME AND
RELIABILITY**



THE MAIN COMPONENTS OF OUR W

1 UNDERCARRIAGE

The extremely rigid design of the undercarriage ensures a long life. The new heavy-duty ZF axles and transmission provide excellent traction and deliver a higher maximum travel speed of 35 kph, reducing travel time between jobsites.

2 UPPERCARRIAGE AND ARMS

The new design of the B Series PRO optimises weight distribution and delivers an outstanding lifting performance on wheels. All the main service points are grouped and easily accessible at ground level. The arm has been redesigned to provide exceptional breakout force, 5% higher than in previous models.

2

3

1



HEELED EXCAVATOR

3

CAB

With the ROPS and FOPS protection and exceptional stability of the B Series PRO, the operator can work with confidence. The comfortable cab and intuitive controls mean that they can maintain high productivity during long hours with minimal fatigue.

4

ENGINE & HYDRAULICS

The high performance, large displacement FPT Industrial engines deliver high torque and power. The 3-pumps hydraulic system maximises swing performance with a dedicated swing pump delivering exceptional efficiency and fast cycles.

4

WE170B
PRO

FAST, POWERFUL AND STABLE

ENGINE AND HYDRAULICS: A PERFECT MATCH

The B Series PRO wheeled excavators run high performance in every working condition, thanks to:

- the large displacement FPT engines, that delivers high torque and power
- the new 3-pumps hydraulic system, that allows simultaneous and fast movements in every working conditions
- the electronic pump management system, that grants always the best match between engine and hydraulic power, minimizing the fuel consumption and the engine load.

In addition to this, the large displacement engine and the 3-pumps hydraulic system result in less wear, increasing the machine's reliability.

AUTOMATIC POWER BOOST

The automatic power boost kicks in when more power is needed, increasing pressure up to 370 bar.



UNDERCARRIAGE

The undercarriage is designed extremely rigid for a long lifetime. Four undercarriage structures are available to provide the best solution according to customer needs: rear blade, rear stabilizers, rear stabilizers and front blade, front and rear stabilizers (WE170B PRO only). The travel motor, the transmission and the hydraulic lines are well protected. The heavy-duty axles and higher ground clearance also contribute to the B Series PRO's reliability and durability. In addition the new heavy-duty ZF axles and transmission provide excellent traction and deliver a higher maximum travel speed of 35 kph, reducing travel time between jobsites.

NEW, SAFE AND RELIABLE DESIGN

The new design of the B Series PRO optimises weight distribution and minimises the offset of the undercarriage, resulting in exceptional stability and equally high lifting performance at the front and the rear.

All these features combine to deliver an outstanding lifting performance on wheels. The arm, available in three lengths for each model, has been redesigned to improve the durability and to provide exceptional breakout force, 5% higher than in previous models.



BLADE

The blade with its parallel kinematics protects the surface when stabilizing the machine and the curved shape of the blade makes the material roll away from the machine when levelling, cleaning or dozing.

SMOOTH AND ACCURATE CONTROLS



BRAND NEW CONTROLS FOR HIGH PRECISION

The electro-hydraulic system has been re-engineered and now relies on a single integrated CPU, with new software developed to maximise the machine's uptime and deliver clear diagnostics. The new system and software have successfully completed an extreme testing programme to optimise their performance and reliability.

PROPORTIONAL CONTROL AND NEW JOYSTICKS

The proportional controls and new low-effort joysticks with longer stroke further add to the excellent control characteristics of the B Series PRO in tasks requiring particularly high precision, such as levelling.

3-PUMPS SYSTEM

The 3-pumps hydraulic system with a dedicated pump for full independent swing operation enables the operator to carry out simultaneous movements under every load.



A MULTI-FUNCTION MASTER

The B Series PRO is a true multi-function master. The operator has a choice of working modes to match the requirements of their task. The **adjustable swing speed** enables them to adjust power and brake force according to the operation. For special applications, the swing brake mode is easily permanently engaged with a dedicated switch. When the highest precision is needed, the operator can activate the **levelling mode** on the left joystick.

ATTACHMENT MANAGEMENT

Managing the attachment's flow and pressure is very easy and up to 12 settings can be memorised for later use. With the attachment management system, proportional control and wide variety of possible configurations, the B Series PRO is designed to work with every type of attachment, offering exceptional versatility.

WELCOME ON BOARD



EASY TO USE

The entire cab layout and control design have been developed with the operator in mind, to make the machine's operation intuitive and comfortable. The new dashboard with LCD monitor and screen dedicated to the rear view camera puts the operator in full control of the machine's status. The rational layout of the controls makes it very easy to operate the machine. For example, all travel controls - road mode, creep speed, gear shifting, axle lock - are grouped on a switch pad placed on the steering column. The slider function for the blade and stabilizers is on the right joysticks, together with the travel direction control. The working and simplified swing brake modes are easy to select.



COMFORTABLE

The spacious cab with pneumatic heated seat and large glazed areas offers an extremely comfortable workstation with excellent all round visibility, further enhanced by the rear view camera.

With an automatic air conditioning system a comfortable operating climate inside of the cab is ensured, contributing to the operator's well being every day. A radio with USB connection and bluetooth is included in the cab as well.

GREAT RELIABILITY AND EASY MAIN

The easy serviceability, added to the particular care that has gone into the durability of key components, from the heavy-duty axles to bucket linkages and the new design features such as the electro hydraulic controls and the 3-pumps hydraulic system, contribute to the exceptional reliability and durability of the B Series PRO wheeled excavators.

LOW MAINTENANCE BUSHINGS

The new **low maintenance bushings** result in longer greasing intervals (100 hours on the WE150B PRO and 500 hours for the WE170B PRO) and less downtime for the machine. Additional external bushings made of anti-wear steel provide extra protection to the arm and bucket's long-life internal bushing. When the radial surface becomes worn, these bushings are easy to change, increasing pin and bushing durability while reducing operating costs.



TENANCE



SERVICE POINTS AT GROUND LEVEL

All the main service points are grouped and easily accessible at ground level, so that daily maintenance operations can be completed quickly and efficiently.

RADIATOR LAYOUT

The side-by-side radiator layout results in an extremely reliable cooling performance and makes it easier to clean them. A front net keeps dust away from the radiators, lengthening the interval between cleanings.



CENTRALISED LUBRICATION

There are centralized greasing points for the boom on the upper carriage, accessible from the ground in order to make the maintenance easier and more convenient for the operator.



PROGRESS IN SAFETY

The reinforced structure of the cab complies with ROPS and FOPS standards. Together with the optional front guard it contributes to providing a safe working environment for the operator.

ROPS certified cab - ISO 12117-2
FOPS protection - ISO 10262 level 2



SAFE OBJECT HANDLING

New Holland Wheeled Excavators can be equipped with all the safety devices required by European Standards EN 474-5: 1996 for object handling operations. The optional Object Handling Kit (safety valves on dipper, loading hook and overload warning system) is available, for maximum operator confidence.

WEI50B PRO

SPECIFICATIONS



ENGINE

Net engine power (ISO 14396/ECE R120).....	90 kW / 121 hp
Rated.....	2000 rpm
Make and model.....	CNH F4GE9484D*J601
Type.....	Water-cooled, direct injection type diesel engine with intercooler turbo-charger
Displacement.....	4.5 l
Number of cylinders.....	4
Bore x stroke.....	104 x 132 mm
Maximum torque at 1200 rpm.....	525 Nm

Remote engine oil filter for easy replacement

Auto-Idling selector returns engine to minimum rpm when all controls are in neutral position

-25° C outside temperature start as standard equipment

The engine complies with 97/68/EC standards STAGE IIIA



ELECTRICAL SYSTEM

Voltage.....	24V
Batteries.....	2 x 12V
Battery rating (each).....	100 Ah
Alternator.....	70 A
Starter motor.....	4 kW



TRANSMISSION

	km/h	km/h
Max Road travel speed	20	35
Max Field travel speed	5	8
Creep speed	2.5	2.5
Maximum drawbar pull (field).....	92 kN	
Power Shift multi-disc gearbox shiftable under load.		
Automatic or manual gear shift control.		
Travel mode automatically engaged by pressing accelerator pedal.		



HYDRAULIC SYSTEM

Primary pumps.....	3 variable displacement, axial piston
Total maximum flow.....	352 l/min (2 x 140 + 72)
Auxiliary low flow, optional (on/off).....	22 l/min
Auxiliary medium flow, optional (proportional).....	80 l/min
Implement /travel pressure.....	340/370 bar
Power Boost.....	370 bar
Swing circuit pressure.....	360/390 bar
Pilot pump.....	45 bar
Boom cylinder mono.....	100 x 1028 mm
Boom cylinder 2-piece boom.....	100 x 972 mm
Arm cylinder.....	115 x 1120 mm
Bucket cylinder.....	95 x 903 mm
Positioning cylinder.....	135 x 645 mm
Cylinder end stroke damping.	
Electrohydraulic servo-control.	
Three-pump hydraulics with two main pumps and separate swing pump. 8 selectable power stages with permanent Power Boost in lift stages: Low idle, Lift 1, Lift 2, Eco 1, Eco 2, Eco 3, Heavy, Roadtravel	
Levelling mode for smooth operation.	
Adjustable swing acceleration (power) and deceleration (brake)	
Automatic power increase in the drive mode.	



SWING DRIVE

Swing speed.....	9 rpm
Swing torque (SAE J1371).....	36 kNm
The swing function is operated by a hydraulic closed circuit coupled with a mechanical reducer integrating an automatic static brake.	
The hydro-static swing brake is adjustable in 3 settings.	



BRAKES

Service brakes: play free, oil bath multi disc type integrated in all four wheel hubs.

Work brake: acts on service brakes and locks front axle oscillation.

Parking brake: spring type mechanical acting on the transmission.

Emergency brake: double braking circuit and automatic parking and brake actuation with the engine shut down.



STEERING

Type.....	ORBITROL with safety valve
Pump.....	gear type
Steering cylinder.....	double effect, integrated in axle



TYRES

Twin tyres.....	10.00-20/80-22.5
Single tyres.....	18R 19.5, 600/40-22.5
Tyre availability can be limited by local homologation.	



CAPACITIES

Engine oil.....	12.5 l
Cooling system.....	22 l
Fuel tank.....	190 l
Hydraulic system (incl. tank).....	200 l for mono 210 l for triple articulation



CAB AND CONTROLS

Sound suppressed cab with modern design, integrated ROPS and standard FOPS.

Rear View Camera with dedicated screen

Control panel with LCD monitor integrating error diagnosis function and analogical gauges for engine cooling temperature and fuel level.

Incline adjustable steering column.

Ergonomic design of armrests and foot pedals, armrest adjustable.

Operator's seat individually adjustable in height and inclination.

Tilttable left console. Standard pneumatic and heated seat.

Radio with Bluetooth.

Automatic air conditioning.

DIMENSIONS

equipped with twin tires 10.00 - 20

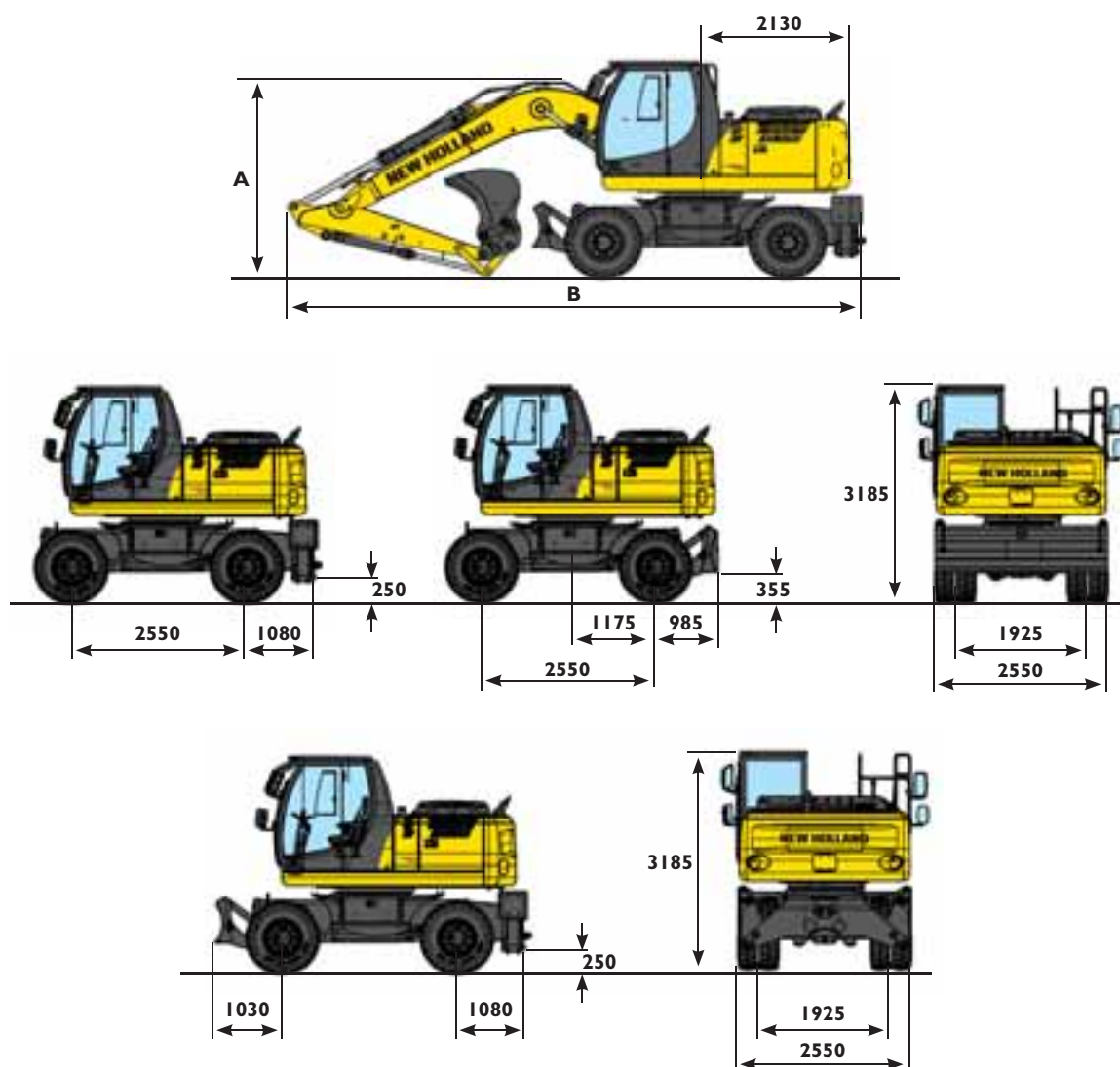

ARM		TRIPLE ARTICULATION			MONOBOOM		
		2100	2450	2950	2100	2450	2950
A	mm	2620	2710	3050	2890	3115	3605
B - with rear blade	mm	8075	8085	8055	7850	7880	7895
B - with rear stabilizers	mm	8240	8250	8220	8015	8045	8065

OPERATING WEIGHT

2,55 axle width include bucket 480 kg and quick coupler 250 kg (with 10.00-20)

ARM		TRIPLE ARTICULATION			MONOBOOM		
		2100	2450	2950	2100	2450	2950
Rear blade	kg	15450	15550	15600	15100	15200	15250
Stabilizers	kg	15750	15800	15850	15400	15500	15550
Blade and stabilizers	kg	16300	16350	16400	16000	16050	16100

DIGGING PERFORMANCE

TRIPLE ARTICULATION

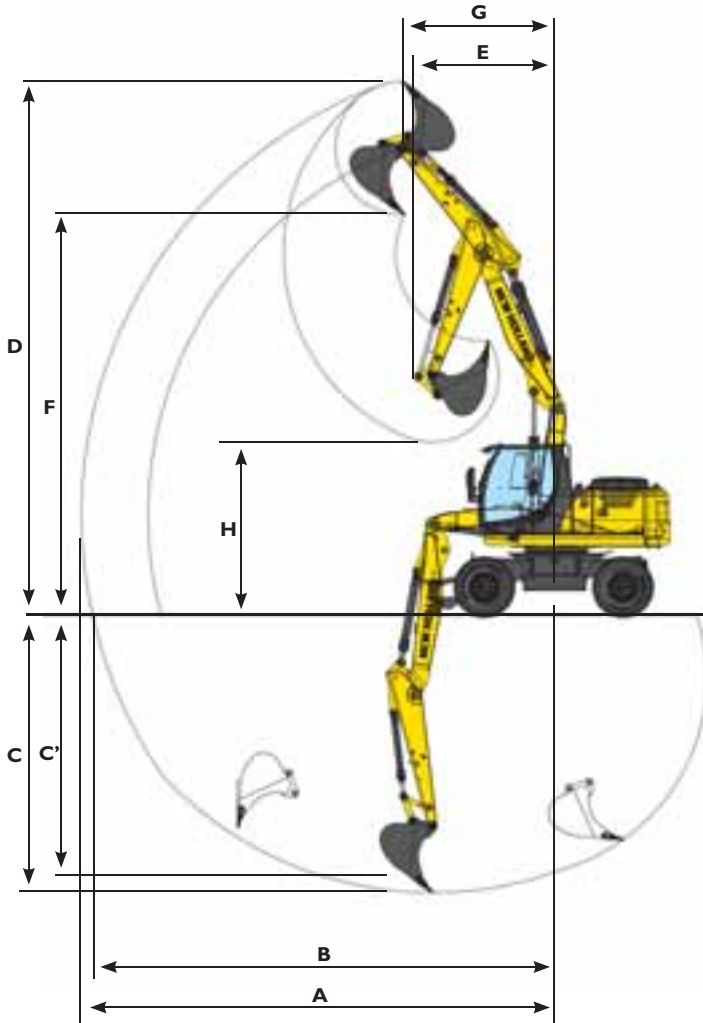

MONOBOOM

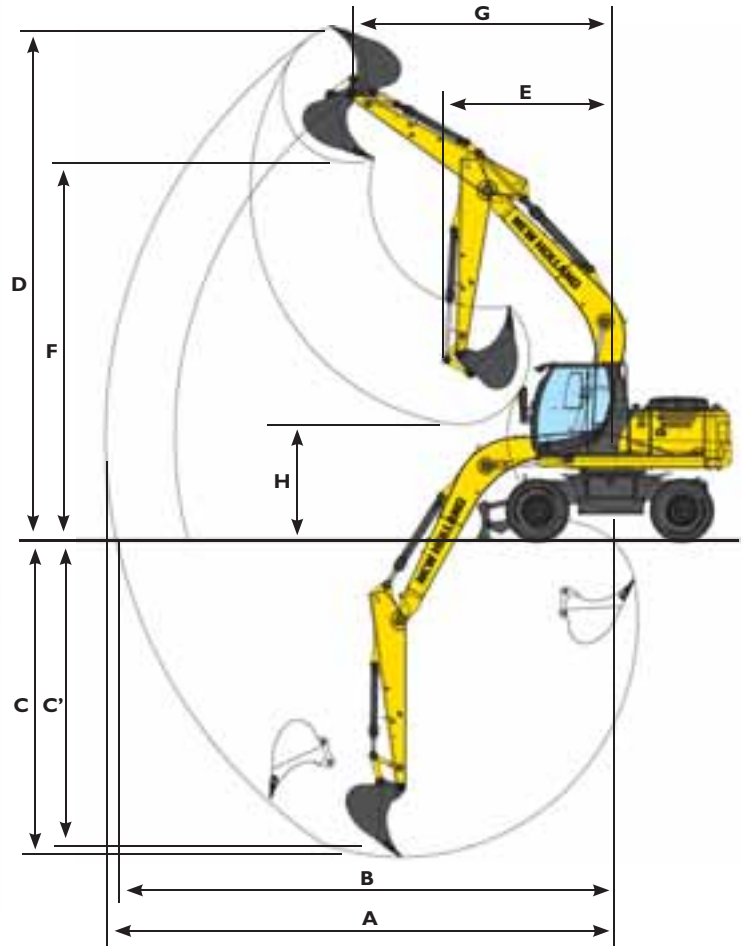

ARM		TRIPLE ARTICULATION			MONOBOOM			
		2100	2450	2950	2100	2450	2950	
A	- Max. digging reach	mm	8400	8800	9300	8200	8500	9000
B	- Max. digging reach at ground level	mm	8300	8600	9100	8000	8300	8800
C	- Max. digging depth	mm	4900	5200	5700	4900	5300	5800
C'	- Max. depth of cut for 8° level bottom	mm	4800	5100	5600	4700	5100	5600
D	- Max. digging height	mm	9600	9900	10300	8600	8800	9200
E	- Min. front swing radius	mm	2450	2600	3000	2750	2800	3050
F	- Max. loading height	mm	7100	7400	7900	6200	6400	6800
G	- Front swing radius at max height	mm	2390	2580	2810	3755	4025	4390
H	- Max. loading height (arm retracted)	mm	3500	3200	2900	2900	2600	2100

BREAKOUT FORCE - ISO

ARM		2100	2450	2950
Bucket	daN	9730	9730	9730
Dipperstick	daN	7940	7170	6390

WEI70B PRO

SPECIFICATIONS

ENGINE

Net engine power (ISO 14396/ECE R120) 105 kW / 141 hp
Rated 2000 rpm
Make and model CNH F4GE9684D*J602
Type Water-cooled, 6 cylinder direct injection type diesel engine with intercooler turbo-charger
Displacement 6.7 l
Number of cylinders 6
Bore x stroke 104 x 132 mm
Maximum torque at 1200 rpm 575 Nm

Remote engine oil filter for easy replacement

Auto-Idling selector returns engine to minimum rpm when all controls are in neutral position

-25° C outside temperature start as standard equipment

The engine complies with 97/68/EC standards STAGE IIIA

ELECTRICAL SYSTEM

Voltage 24V
Batteries 2 x 12V
Battery rating (each) 100 Ah
Alternator 70 A
Starter motor 4 kW

TRANSMISSION

	km/h	km/h
Road travel speed	20	35
Field travel speed	5	8
Creep speed	2.5	2.5

Maximum drawbar pull (field) 92 kN
Power Shift multi-disc gearbox shiftable under load.
Automatic or manual gear shift control.
Travel mode automatically engaged by pressing accelerator pedal.

HYDRAULIC SYSTEM

Primary pumps 3 variable displacement, axial piston
Total maximum flow 360 l/min (2 x 144 + 72)
Auxiliary low flow, optional (on/off) 22 l/min
Auxiliary medium flow, optional (proportional) 80 l/min
Implement /travel pressure 340/370 bar
Power Boost 370 bar
Swing circuit pressure 370/390 bar
Pilot pump 45 bar
Boom cylinder mono 110 x 1170 mm
Boom cylinder 2-piece boom 110 x 1020 mm
Arm cylinder 115 x 1290 mm
Bucket cylinder 100 x 1025 mm
Positioning cylinder 155 x 745 mm
Cylinder end stroke damping.
Electrohydraulic servo-control.
Three-pump hydraulics with two main pumps and separate swing pump. 8 selectable power stages with permanent Power Boost in lift stages: Low idle, Lift 1, Lift 2, Eco 1, Eco 2, Eco 3, Heavy, Roadtravel
Levelling mode for smooth operation.
Adjustable swing acceleration (power) and deceleration (brake)
Automatic power increase in the drive mode. Automatic power increase in the drive mode.

SWING DRIVE

Swing speed 8,6 rpm
Swing torque (SAE J1371) 42,4 kNm
The swing function is operated by a hydraulic closed circuit coupled with a mechanical reducer integrating an automatic static brake.
The hydro-static swing brake is adjustable in 3 settings.

BRAKES

Service brakes: play free, oil bath multi disc type integrated in all four wheel hubs.

Work brake: acts on service brakes and locks front axle oscillation.

Parking brake: spring type mechanical acting on the transmission in all four wheel hubs.

Emergency brake: double braking circuit and automatic parking and automatic parking brake actuation with the engine shut down.

STEERING

Type ORBITROL with safety valve
Pump gear type
Steering cylinder double effect, integrated in axle

TYRES

Twin tyres 10.00-20/80-22.5
Single tyres 18R 19.5, 600/40-22.5
Tyre availability can be limited by local homologation.

CAPACITIES

Engine oil 15 l
Cooling system 22 l
Fuel tank 274 l
Hydraulic system (incl. tank) 215 l for mono
230 l for triple articulation

CAB AND CONTROLS

Sound suppressed cab with modern design, integrated ROPS and standard FOPS.

Control panel with LCD monitor integrating error diagnosis function and analogical gauges for engine cooling temperature and fuel level.
Incline adjustable steering column.

Ergonomic design of armrests and foot pedals, armrest adjustable.

Operator's seat individually adjustable in height and inclination.

Tiltable left console. Standard pneumatic and heated seat.

Radio with Bluetooth.

Automatic air conditioning.

DIMENSIONS

equipped with twin tires 10.00 - 20

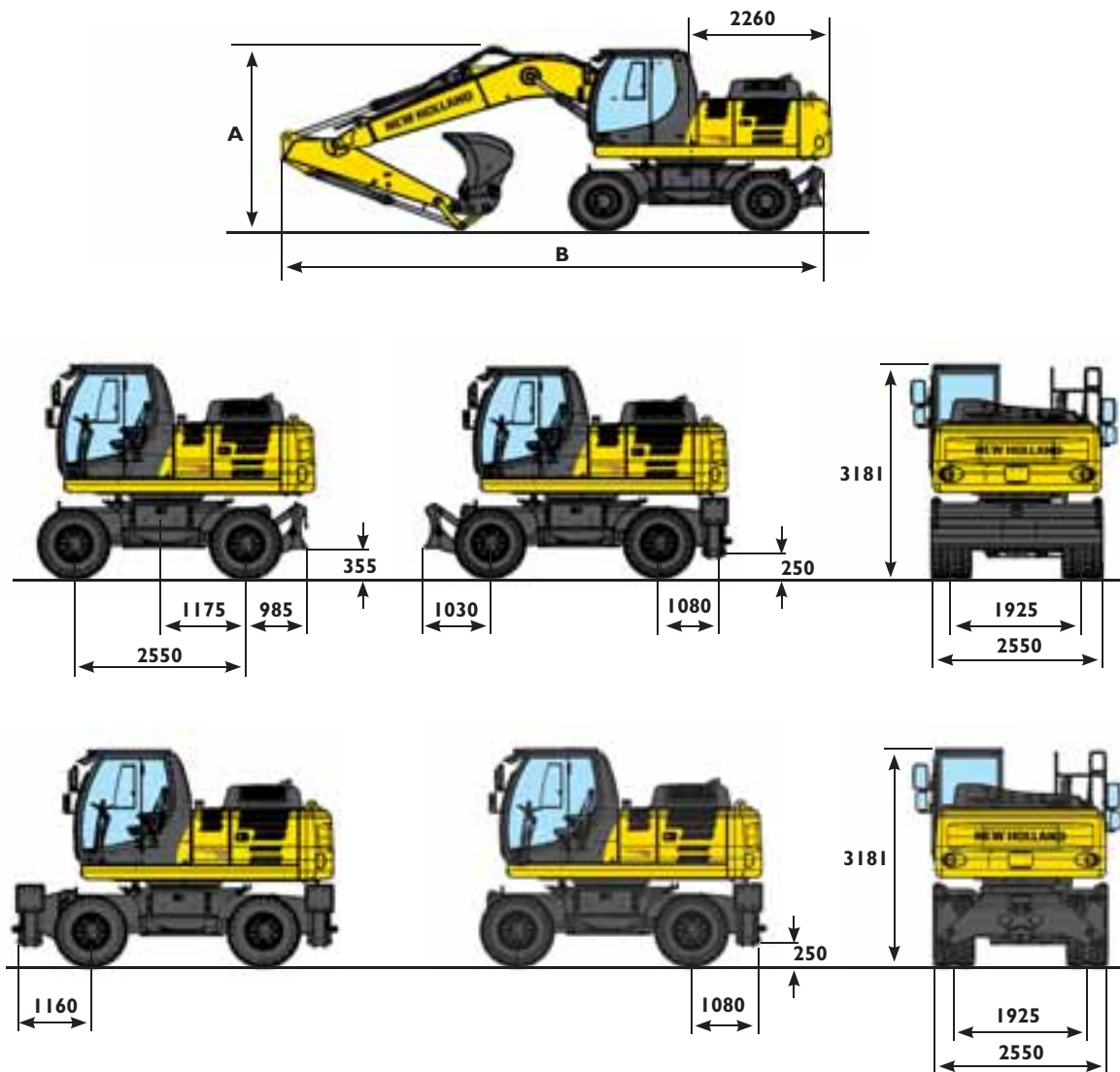

ARM		TRIPLE ARTICULATION			MONOBOAM		
		2200	2600	3100	2200	2600	3100
A	mm	2870	2825	3315	3110	3075	3730
B - with rear blade	mm	8670	8600	8585	8635	8575	8575
B - with rear stabilizers	mm	8730	8660	8645	8695	8635	8635

OPERATING WEIGHT

2,55 axle width include bucket 480 kg and quick coupler 250 kg (with 10.00-20)

ARM		TRIPLE ARTICULATION			MONOBOAM		
		2200	2600	3100	2200	2600	3100
Rear blade	kg	17100	17150	17220	16950	17000	17070
Stabilizers	kg	17400	17450	17520	17250	17300	17370
Blade and stabilizers	kg	18000	18050	18120	17850	17900	17970
Stabilizers rear and front	kg	18400	18450	18520	18250	18300	18370

DIGGING PERFORMANCE

TRIPLE ARTICULATION

MONOBOOM

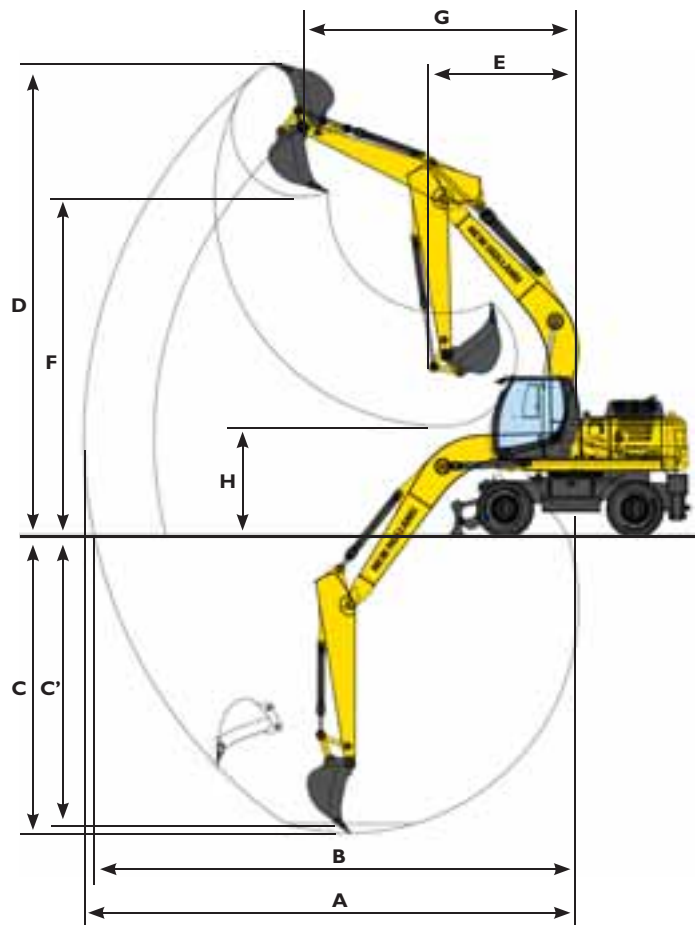
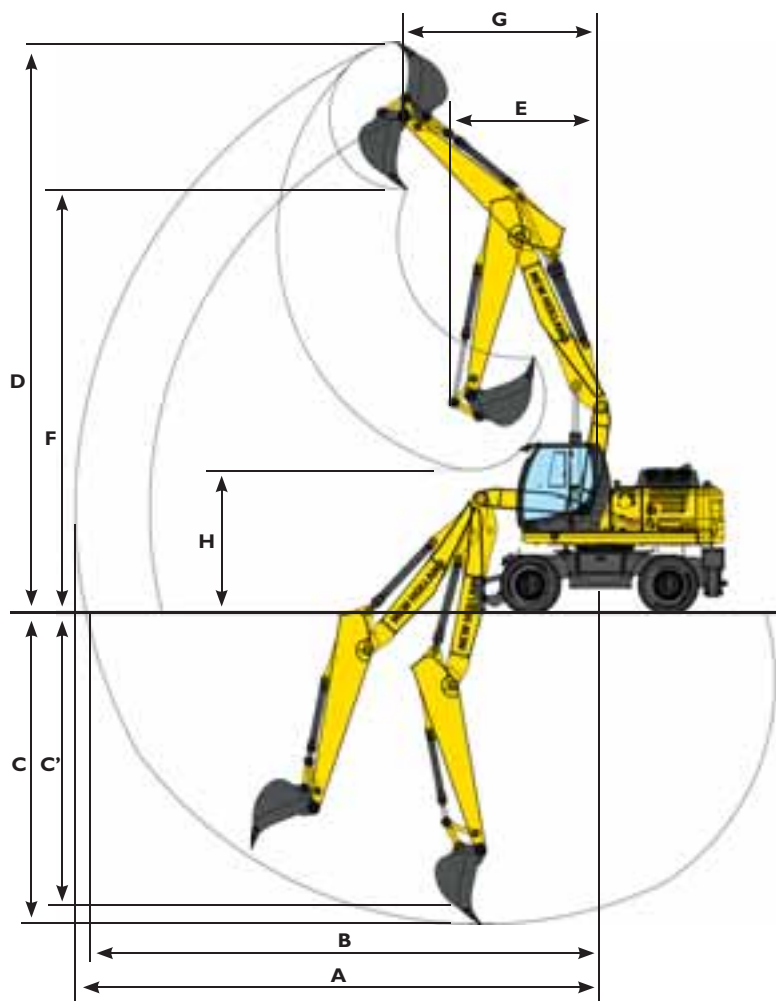

ARM		TRIPLE ARTICULATION			MONOBOOM			
		2200	2600	3100	2200	2600	3100	
A	Max. digging reach	mm	8950	9290	9780	8840	9150	9630
B	Max. digging reach at ground level	mm	8730	9080	9580	8620	8940	9430
C	Max. digging depth	mm	4910	5290	5790	4940	5330	5840
C'	Max. depth of cut for 8° level bottom	mm	4800	5180	5690	4710	5120	5660
D	Max. digging height	mm	9970	10190	10580	8900	8980	9270
E	Min. front swing radius	mm	3060	2810	2870	3340	2950	2860
F	Max. loading height	mm	7220	7450	7840	6280	6370	6650
G	Front swing radius at max height	mm	3060	3400	3710	4540	4930	4540
H	Max. loading height (arm retracted)	mm	3660	3130	2630	3070	2640	2140

BREAKOUT FORCE - ISO

ARM		2200	2600	3100
Bucket	daN	10900	10900	10900
Dipperstick	daN	8700	7500	6600

STANDARD EQUIPMENT

- Latest generation FPT Stage III / Tier 3 diesel engine
- Direct injection with turbo charger and charge air cooling
- Air filter with safety cartridge
- Engine filters (oil, fuel and water separator) in remote position
- Auto-idling system
- Cold starting equipment (-25°C)
- Pump management system by power limit control
- Electrohydraulic servo control
- 3-pumps hydraulic system with two service pumps and separate swing pump
- Auto Powerboost system
- 8 selectable power stages with permanent Power Boost in lift stages
- Automatic power increase in road travel mode
- Automatic battery main switch (coupled to ignition key)
- Electronic immobiliser (PIN code)
- 12V electrical auxiliary supply in cab
- Swing hydrostatic braking
- Automatic / permanent swing brake modes
- Swing drive with low-wearing disc brake
- Adjustable swing acceleration (power) and deceleration (brake)
- Cab according ROPS ISO 12117-2: 2008
- FOPS Level 2
- Noise-insulated and viscous mounted cab
- Tinted safety glazing all around, full up and over windscreen
- Sun blinds, large roof window, transparent rain protection
- Automatic air conditioning
- Rear View Camera with dedicated screen
- Radio with Bluetooth
- Control panel with LCD monitor integrating error diagnosis function and analogical gauges for engine cooling temperature and fuel level
- Ergonomic design of arm rests and foot pedals
- Air suspension seat individually adjustable for height and incline
- Consoles adjustable for height and length
- Forward/Reverse shifting on right joystick
- Centralised and independent control of blade and stabilizers on right joystick
- 2 front headlights (cab mounted)
- Road travel lights (front and rear)
- Robust, shielded arc-welded, modular chassis in box section design
- Power Shift gear box with manual / automatic gear shifting
- Heavy duty axles with brakes for play-free work
- Hydrostatic travel braking
- Creeper speed
- Large toolbox under the step (right side)
- Encased ball bearing slew ring with long-life lubrication
- Manual / automatic axle locking system
- Safety valves on boom cylinders
- Cylinders with end-stroke damping system
- Long interval greasing bushings
- Centralized greasing nipples on upperframe and boom
- 2 working lights on boom

OPTIONS

- Electric diesel filling system
- Hydraulic circuit for hammer / shears
- Hydraulic circuit for grab rotation 22 l/min - ON/OFF control
- Hydraulic circuit for grab rotation 80 l/min - PROPORTIONAL control
- Quick coupler provision on upperframe
- Mineral hydraulic oil
- Biodegradable hydraulic oil (Panolin)
- Front Guard Protective system FGPS
- Rear View Camera with dedicated screen (mandatory for EUR, Turkey and Israel)
- 20 km/h speed
- 35 km/h speed
- Single or twin tyres
- Dozer blade with parallel guidance
- Stabilizers with cylinder protection guards
- Transport holder for clamshell grab
- Blade cylinders protection guard
- One piece boom, triple articulation (2 piece boom)
- Arms:
 - WE150B: 2100 - 2450 - 2950 mm
 - WE170B: 2200 - 2600 - 3100 mm
- Object handling kit with safety valve on arm cylinder, overloading warnings device and load hook

Note: standard and optional equipment may vary by country. Consult your NEW HOLLAND dealer for specific details.

AT YOUR OWN DEALERSHIP

The information contained in this brochure is intended to be of general nature only. The NEW HOLLAND KOBELCO CONSTRUCTION MACHINERY S.p.A. company may at any time and from time to time, for technical or other necessary reasons, modify any of the details or specifications of the product described in this brochure. Illustrations do not necessarily show products in standard conditions. The dimensions, weights and capacities shown herein, as well as any conversion data used, are approximate only and are subject to variations within normal manufacturing techniques.

Published by NEW HOLLAND KOBELCO CONSTRUCTION MACHINERY S.p.A.
Printed in Italy - MediaCross Firenze - Cod 30672GB - Printed 09/12

Printed on recycled paper
CoC-FSC 000010 CQ Mixed sources



www.newholland.com

